

TOP SECTION VIEW

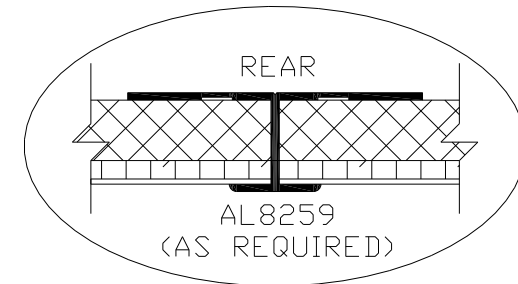
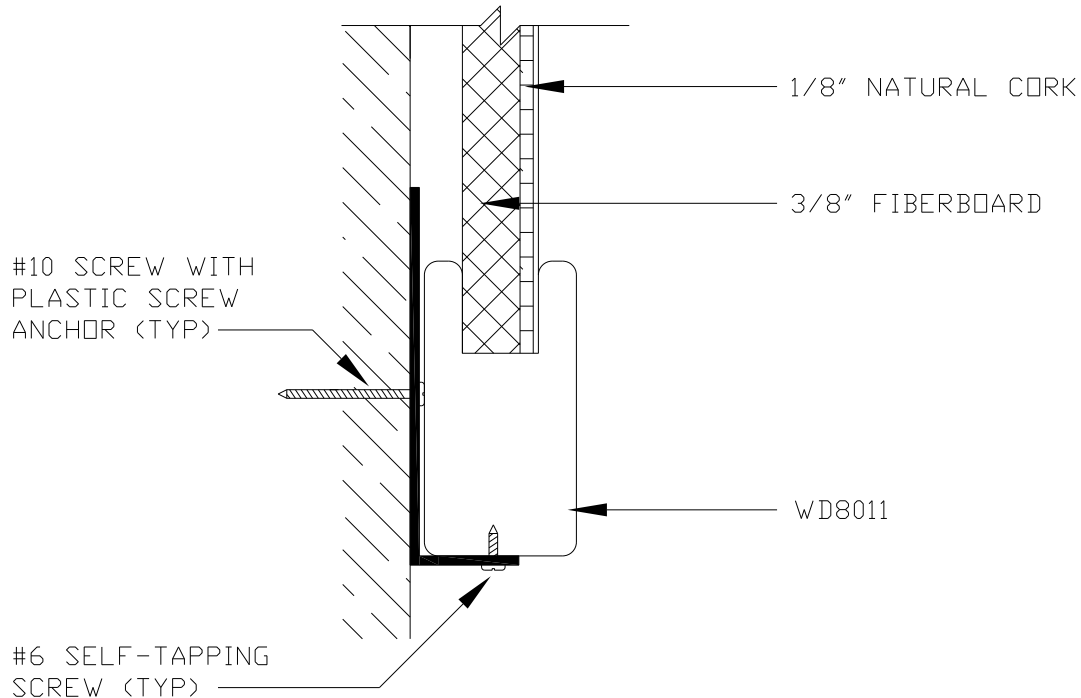

TACKBOARD
SERIES 7502

PROJECT:		-	JOB #	----	
DATE:	--/--/--	DRAWN BY:	TCW	SCALE:	3/4
SUBMITTED FOR:		-	-	-	
MANUFACTURED BY:		MARSH INDUSTRIES, INC.			
		PO BOX 1000 - NEW PHILADELPHIA, OH 44663-5100			
		PH: (330) 308-8865 FAX: (330) 339-5875			
THIS DRAWING IS PROPRIETARY TO MARSH INDUSTRIES, INC. AND IS FURNISHED SUBJECT TO AN EXPRESSED AGREEMENT NOT TO USE OR DISCLOSE, DIRECTLY OR INDIRECTLY, FOR ANY PURPOSE. THIS LEGEND SHALL BE MARKED UPON ANY REPRODUCTION IN WHOLE OR IN PART HEREOF.				SHEET	OF
				-	-